



by Schneider Electric

Installation

Modular Power Distribution Unit

208/120 V with Input and Subfeed Breaker

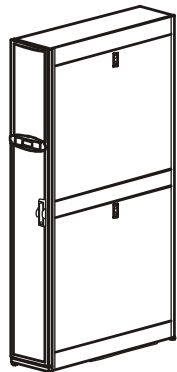

IMPORTANT SAFETY INSTRUCTIONS! SAVE THESE INSTRUCTIONS!

This document contains important instructions that should be followed during installation and maintenance of the Modular Power Distribution Unit (PDU).



Electrical Hazard: Only certified electricians are authorized to connect power to the PDU.



Electrical Hazard: The PDU must be installed in accordance with the National Electrical Code or the Canadian Electrical Code and all applicable local codes.

Level the PDU

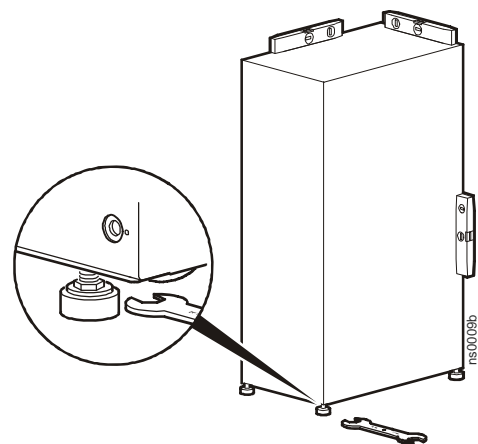

Install the Power Cables

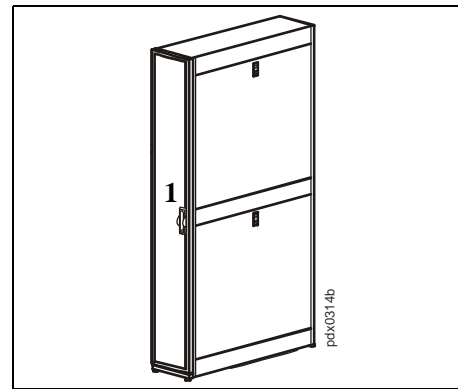

1 Open the rear door of the PDU.

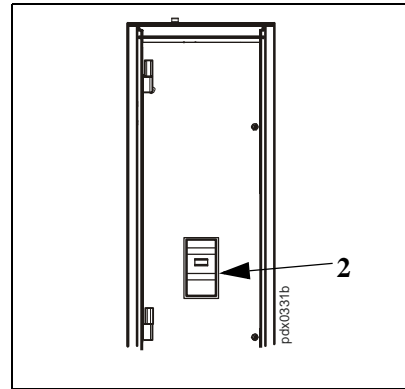

2 Make sure the input breaker is in the OFF (open) position.

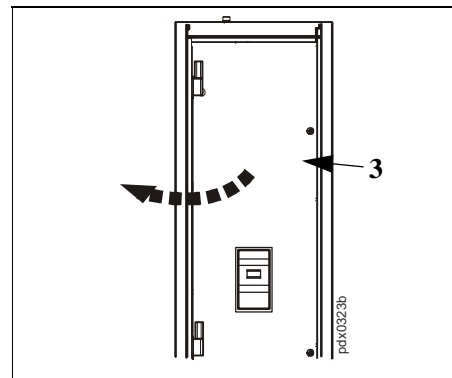

3 Open the safety door to expose the input breaker.

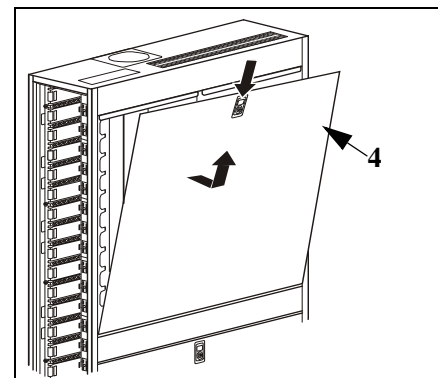

4 Unlock the side panel with the key (provided). Remove side panel to expose mains shield.

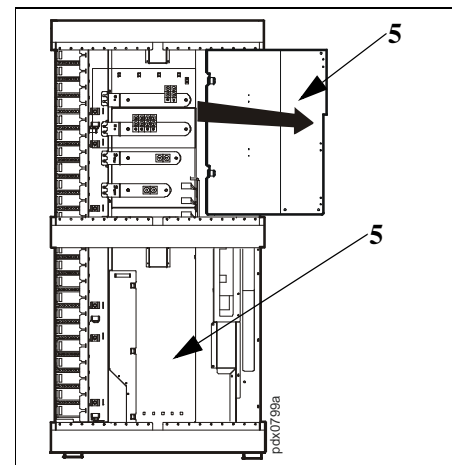

5 Loosen the screws from the mains shield and remove the shield to gain access to the compression terminals. Only remove the bottom shield if the bottom entry is used.

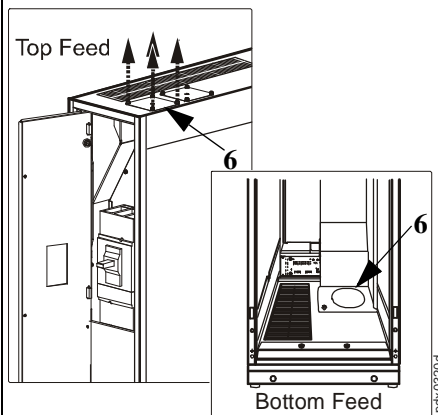

6 Loosen four screws from the rear top plate and remove the plate. Remove the bottom plate for bottom feed installations. Cut or punch a hole in the plate to accommodate a conduit for power cables.



Note: Both top rear plates can be employed to accommodate power cables. Never drill or cut above the PDU.

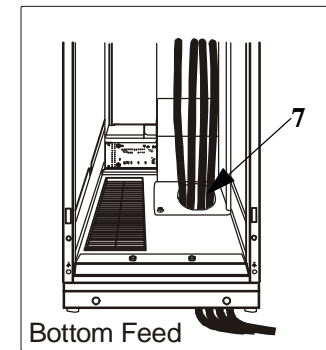
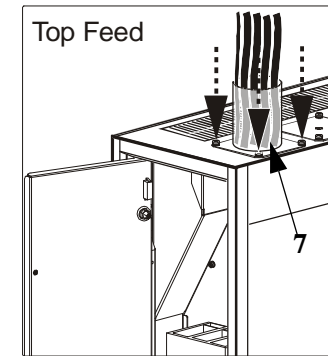

7 Install the conduit and pull the conductors into the PDU from the bottom or the top.

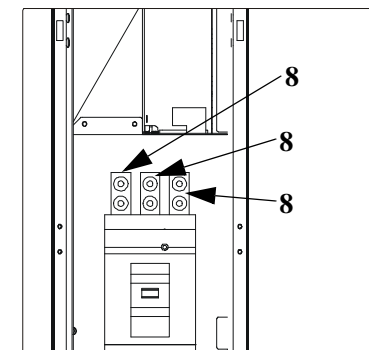

8 Connect the phase (L1, L2, L3) conductors. Torque: 31.1 Nm (275 lb-in).

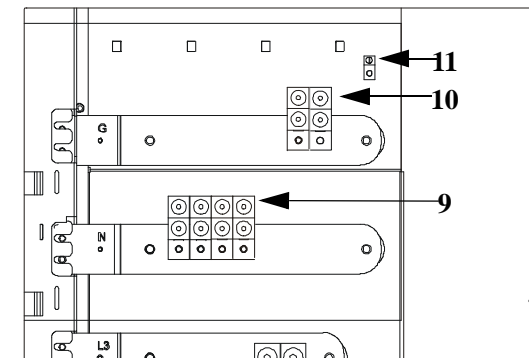

9 Connect the neutral (N) conductor. Torque: 31.1 Nm (275 lb-in).

10 Connect the isolated ground conductor. Torque: 31.1 Nm (275 lb-in).

11 Connect the chassis ground (G) conductor. Torque: 5.6 Nm (50 lb-in).

Replace the mains shield and side panel.

Close the safety door, and then the rear door, of the PDU.

Install the User Contacts



Note: Contact wires from external signaling, alarming, and sensing devices may be connected to the interface board to allow the PDU microprocessor to monitor these devices.

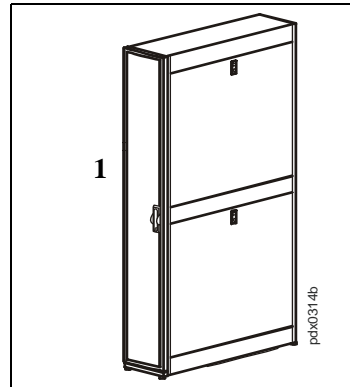

1 Open the front door of the PDU.

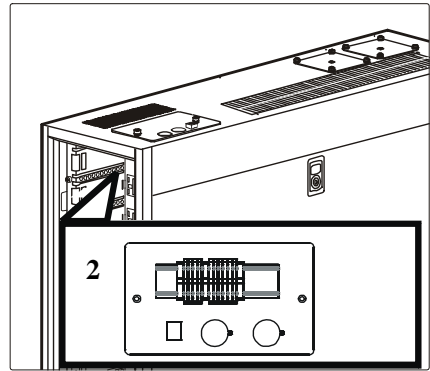

2 Note the location of the terminal block on the underside of a small top plate above the power distribution modules.

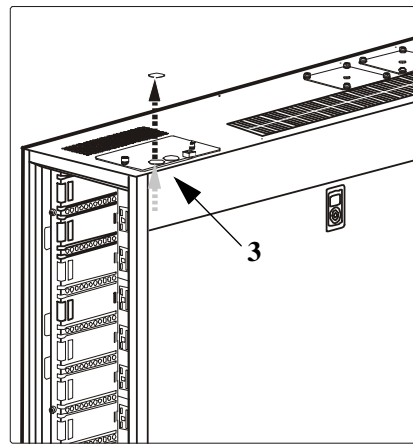

3 Working from inside the PDU enclosure, punch out the 64 mm (3/4 in) knockout in the small top plate.

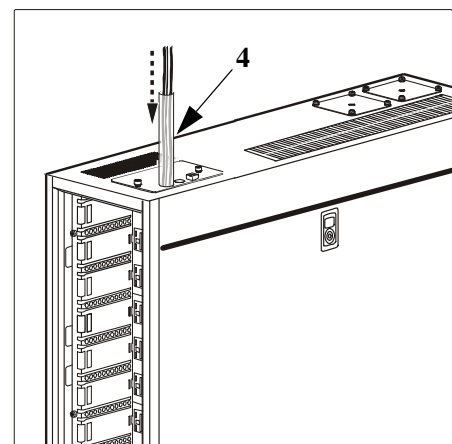

4 Attach conduit containing contact wires from external devices to the knockout.

Factory Terminal Block Wiring										
C1	C2	C1S	C2S	11	12	14	11S	12S	14S	Auxiliary Contact Rating:
120 VAC Shunt Trip	120 VAC Subfeed Shunt Trip	N.C.	N.C.	N.O. Aux	N.O. Subfeed	N.C.	N.C.	N.O. Aux	N.O. Subfeed	0.3 A @ 250 Vdc, 0.8 A @ 125 Vdc
Breakers in the OFF position										
Customer Field Wiring, If Needed										

5 Make connections to appropriately labeled terminals on the terminal block.

Install the Communication Cable

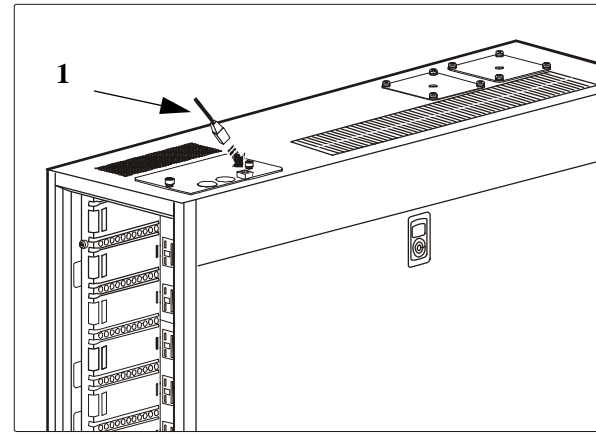

1 Connect one end of the CAT-5 cable to the RJ-45 port on top of the PDU.

2 Connect the other end of the CAT-5 cable to either an InfraStruXure Central, or InfraStruXure Manager server, or a local area network port.

Connect Conductors to the Subfeed Circuit Breaker

The subfeed conductors are installed in the same manner as the Power Cables as shown on page 1. Follow steps 1 through 7.

8 Connect the phase (L1, L2, L3) conductors. Torque 31.1 Nm (275 lb-in).

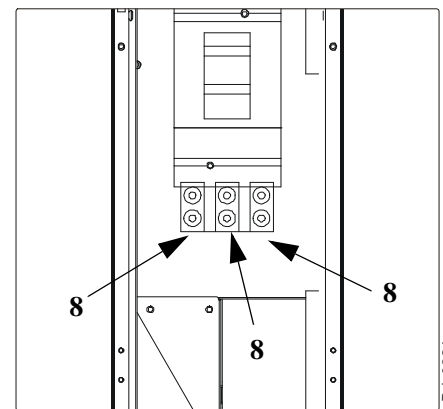

Install Power Distribution Modules



Electrical Hazard: To prevent arcing when removing a Power Distribution Module (PDM) from the panel, set all circuit breakers on that module to OFF (open).



Note: Install only APC-supplied 208/120 V PDMs in the panel of this PDU. APC PDMs can be safely installed in the panel even when the PDU is operational.

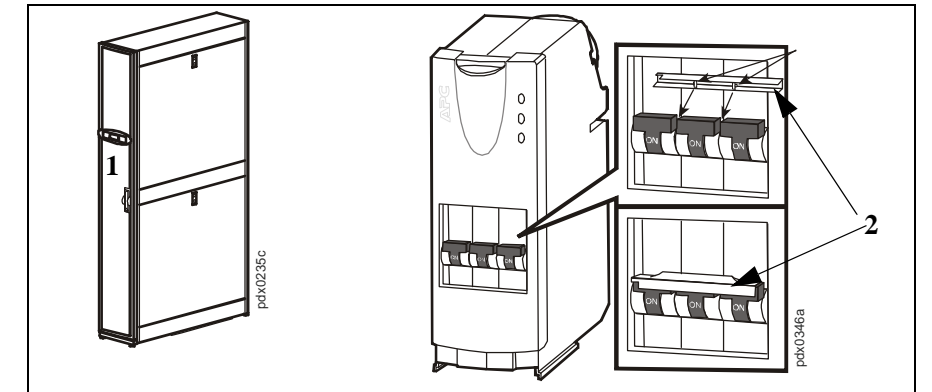

1 Open the front door of the PDU. 2 If your PDM does not include a handle tie, you will need to install one.

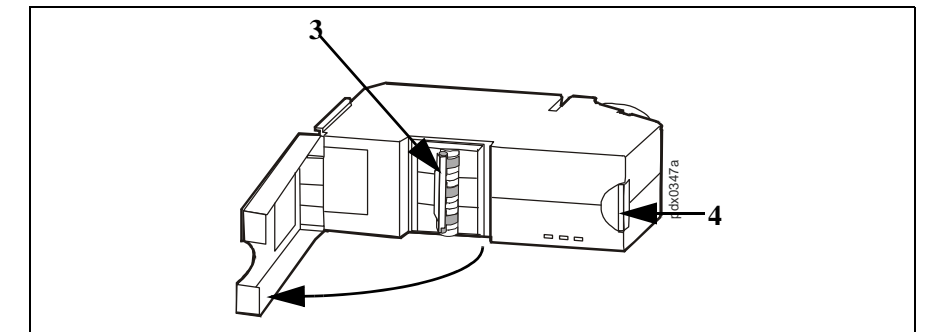

3 Make sure all breakers on the PDM that is being installed are in the OFF (open) position. 4 Press the red button to release the latch then, pull open the latch.

- 5 Install PDMs starting from the bottom of the panel to avoid cable congestion. Select the next available 3-pole position for installation.
- 6 Slide the PDM into the panel using the top and bottom guide tracks for that position. Make sure you slide the PDM all the way into its position.

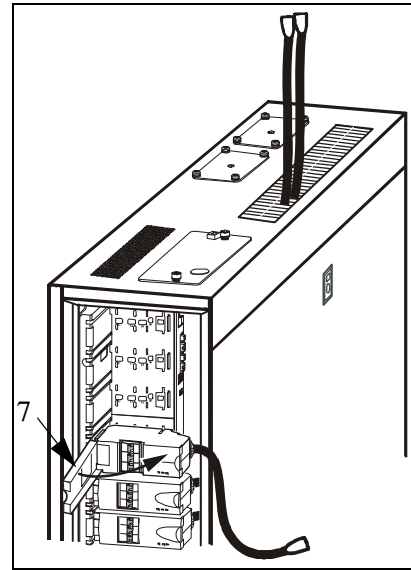
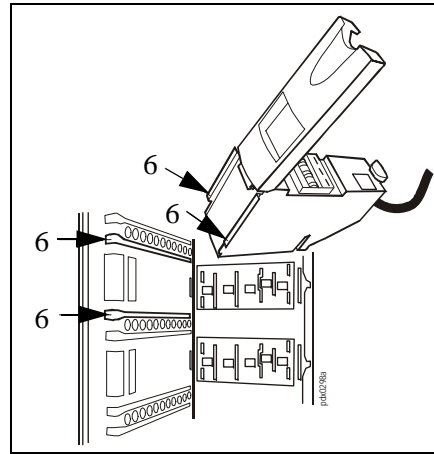

- 7 Close the latch. This will tighten electrical contacts in the PDM against the busbar.

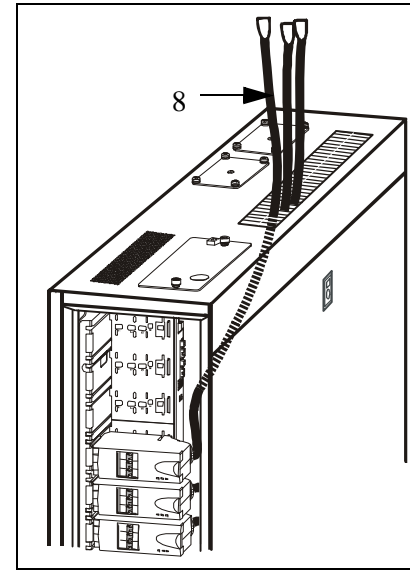

- 8 Feed cable from the PDM through the brush-filled slot in the roof of the PDU.

Note: When installing PDMs near the top of the panel, perform step 8 before steps 6 and 7 to avoid cable congestion between the panel and the slot.

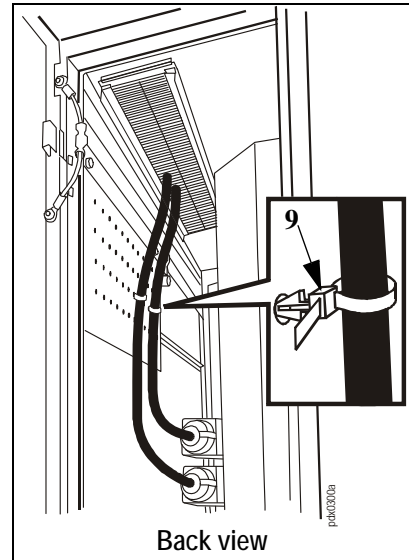

- 9 Use tie wraps to secure loose cables to the enclosure. Connect the PDM cable to the appropriate rack-mount PDU or other equipment.

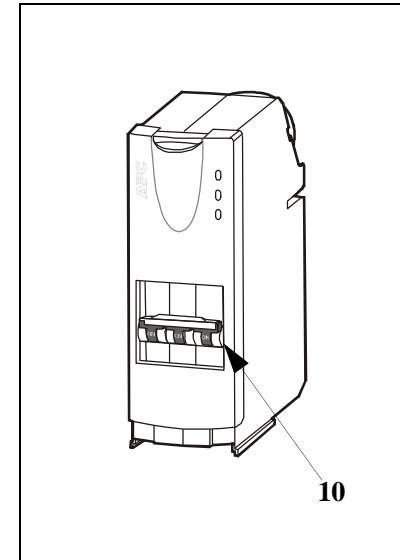

- 10 Set all breakers on the newly installed PDM to the ON (closed) position.

Specifications

AC Input and Subfeed

Input Circuit Breaker	400A
Nominal voltage	208/120 V, 3W + N + G
Frequency	60 Hz
Input and subfeed circuit	320 A
Maximum continuous current	320 A

AC Output

Nominal voltage	208/120 V, 3W + N + G 120 V, 1W + N + G
Maximum continuous current	320 A (PDMs plus subfeed)
Full load rating	115 kVA @ 208 V 3 PH
Power distribution module	208/120 V, 3-pole modules
Power distribution poles	72
Maximum number of PDMs	24
Output cable connections	TC-ER (Tray cable - exposed runs)
Output cable lengths	Various, based on using APC PDMs

320 A, 90°C (194°F) Conductors

Wiring System	Copper
3 CCC, 30°C (86°F) Ambient	Ø&N = (2) 250 kcmil AWG G = (2) 3 AWG
4 CCC, 30°C (86°F) Ambient	Ø&N = (2) 250 kcmil AWG G = (2) 3 AWG
Isolated Ground	(2) 3 AWG

CCC = Current-Carrying Conductors

AWG = American Wire Gauge

kcmils = MCM = Thousands of Circular Mills

Ø = Phase conductor

N = Neutral conductor

G = Ground (Equipment Grounding) conductor

(2) = Two conductors per terminal

Note: Input and subfeed circuit breakers are 100% rated. In accordance with the National Electrical Code, input wiring shall be rated 90°C (194°F) minimum and shall be sized for ampacity in accordance with the 75°C (167°F) columns of conductor ampacity tables.

Environment and Compliance

Operating Environment	Protected from water and conductive contaminants
Temperature	Operating: 0 to 40°C (32 to 104°F) Storage: 0 to 45°C (32 to 113°F)
Humidity	Operating: 0 to 95%, non-condensing Storage: 0 to 95%, non-condensing
Elevation	10 000 m (3,000 ft)
Certification	Listed and cUL by Underwriters Laboratories Inc.

Note: Conductor sizing in this manual is based on an ambient temperature of 30°C (86°F). If the ambient temperature of your datacenter is greater than 30°C (86°F), larger conductors are to be used in accordance with the Correction Factors of the National Electric Code and the Canadian Electric Code. Conductor sizing in this manual is based on conductors and circuit breaker terminals rated 75°C (167°F).

Regulatory Agency Approval

This equipment has been tested and found to comply with the limits for a Class A digital device, pursuant to Part 15 of the FCC Rules. These limits are designed to provide reasonable protection against harmful interference when the equipment is operated in a commercial environment. This equipment generates, uses, and can radiate radio frequency energy and, if not installed and used in accordance with the Installation Guide, may cause harmful interference to radio communications. Operation of this equipment in a residential area is likely to cause harmful interference, in which case the user will be required to correct the interference at his own expense.

This Class A digital apparatus complies with Canadian ICES-003.

Cet appareil numérique de la classe A est conforme à la norme NMB-003 du Canada.

This is a Class A Product. In a domestic environment this product may cause interference, in which case the user may be required to take adequate measures.

Appendix

Install filler plates

Install APC filler plates (part number 870-14628) to properly cover 3-pole panel positions that are not occupied by a PDM.

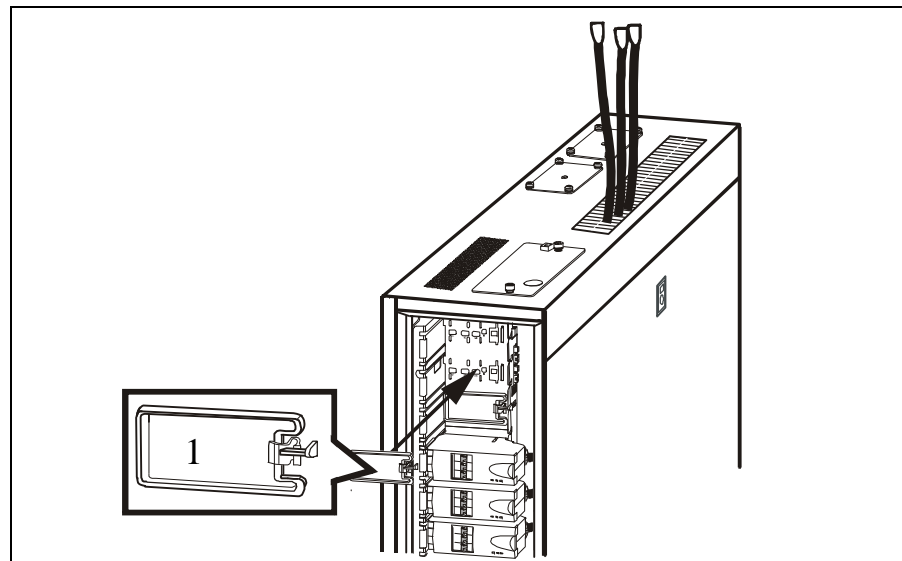

- 1 Position the filler plate sideways in front of the open 3-pole panel position (the top is on the right, the bottom on the left, as shown).
- 2 Insert the bottom of the filler plate into the slot on the left side of the panel position.
- 3 Push the top of the filler plate forward until its locking mechanism snaps securely into the panel.

Install shielding troughs

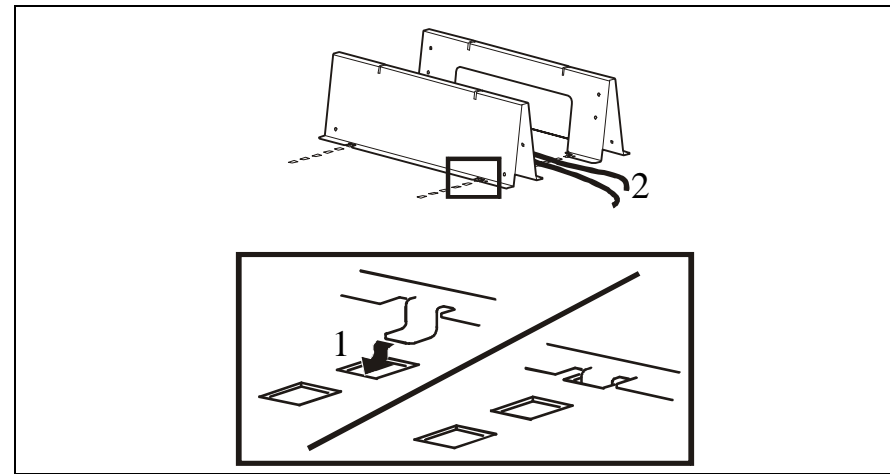

- 1 Snap an APC-provided trough into slots on the roof of the PDU. The tabs at the base of the trough must fit securely into the slots.



Note: Be sure to properly align the PDU trough with troughs installed on top of the enclosures located alongside the PDU.

- 2 Feed the PDM cables through the roof of the PDU and into the trough system for connection with the appropriate rack-mount PDUs.

APC Worldwide Customer Support

Customer support and warranty information is available at the APC Web site, www.apc.com.

© 2011 APC by Schneider Electric. APC, the APC logo, and others are owned by Schneider Electric Industries S.A.S., American Power Conversion Corporation, or their affiliated companies. All other trademarks are property of their respective owners.