

The Different Types of UPS Systems

White Paper 1

Version 9

by Jim Spitaels
Linda Zhang
Paul Lin

Executive summary

There is much confusion in the marketplace about the different types of static uninterruptible power supplies (UPSs) and their characteristics. The IEC 62040-3 UPS performance standard classifies all UPSs based on their output characteristics. In this paper, we summarize the most relevant parts of the IEC standard, then describe 5 types of UPSs, provide practical applications of each, and discuss their advantages and disadvantages. With this knowledge, you can make an educated decision about the best UPS type for your application.

RATE THIS PAPER



Introduction

There are two main categories of uninterruptible power supplies (UPSs)¹, static and rotary. As the name implies, static UPSs do not have any moving parts in their converters. Whereas, rotary UPS use mechanical parts that rotate, such as motor/generators, to function. This paper focuses only on static UPSs. For more information on rotary UPSs see White Paper 92, [Comparison of Static and Rotary UPS](#). The varied types of static UPSs and their claimed attributes often cause confusion for those selecting them for critical applications such as data centers, hospitals, airports, etc. Such confusion might lead one to believe that a given UPS type is capable of a certain performance level or function that it, in fact, cannot achieve. Many misunderstandings are cleared up when the output characteristics are properly identified for each of the different types of UPSs.

This paper first discusses the IEC UPS performance standard which is used as a means of classifying various types of UPSs. Since the output performance is the primary reason UPSs are selected for specific applications, it is important to have this background knowledge from the IEC standard before selecting a UPS. We then describe each of the five UPS types in the marketplace including brief explanations about their output characteristics and how each topology works. This will help you to properly identify and compare UPSs for various applications.

UPS output performance

In order to help manufacturers accurately represent their products and to help users understand exactly what they are buying, the [IEC 62040-3: UPS - Method of specifying the performance and test requirements](#) standard was created. It classifies the output performance of all types of static UPSs² and provides test requirements to validate their performance. Output performance is specified in three parts, AAA-BB-CC, which are described in detail in the following subsections.

Part 1: Input dependency (AAA)

The first part of UPS output performance classification is input dependency (i.e., how the UPS's output voltage is dependent upon the quality of the input voltage). The input dependency of a UPS falls into one of three classifications³:

- Voltage and Frequency Dependent (VFD),
- Voltage Independent (VI), and
- Voltage and Frequency Independent (VFI).

Each class has different capabilities for solving power problems such as power interruptions, voltage sags and swells, etc. **Table 1** illustrates how a UPS's input dependency performance relates to seven common types of power problems. For detailed information on these seven types of power problems see White Paper 18, [The Seven Types of Power Problems](#).

From **Table 1**, it's clear that a VFI UPS is the highest performance among the three classifications because it can provide protection from power interruptions and perform both voltage and frequency regulation. For more information on the relationship between input and output voltage and frequency for the VFD, VI, and VFI classifications, see **Appendix Figure A1**.

¹ A UPS is normally referred to as an uninterruptible power supply, but it's also known as uninterruptible power system.

² Note that rotary UPS are covered in IEC 88528-11:2004 Reciprocating internal combustion engine driven alternating current generating sets - Part 11: Rotary uninterruptible power systems - Performance requirements and test methods.

³ See the **Appendix** for further information

Table 1

Summary of UPS capabilities for protecting the load from power problems by input dependency performance classification

7 types of power problems	Problems addressed by classification		
	VFD	VI	VFI
Power interruptions	✓	✓	✓
Voltage sags and swells	✓	✓	✓
Voltage transients	*	✓	✓
Sustained over- and under-voltages	✗	✓	✓
Voltage waveform distortion	✗	**	✓
Voltage fluctuations	✗	**	✓
Frequency variations	✗	✗	✓

* Some VFD UPSs may include surge suppression and filtering components to address voltage transients.

** Within the VI category, only on-line UPSs are able to address voltage fluctuation and waveform distortion problems, such as harmonics, inter-harmonic, notching, etc. We will discuss this further in the “UPS types” section.

Part 2: Output voltage waveform (BB)

The second part of UPS output performance classification is output voltage waveform performance in normal mode (first character – i.e. when operating from utility power) and in stored energy mode (second character – i.e. when operating from battery power).

Output voltage waveforms fall into one of three classifications:

- Low THD sine wave denoted by S,
- Medium THD sine wave denoted by X, and
- Non-sinusoidal (e.g. step or square) wave denoted by Y.

For more detail regarding the nine possible combinations, see **Appendix Table A1**. The two common waveform types are sinusoidal (S) and non-sinusoidal (Y). Nearly all UPSs rated 2 kVA and above are classified SS whereas many consumer-oriented UPSs rated below 2 kVA are classified SY.

Part 3: Dynamic output performance (CC)

The third part of UPS output performance classification is dynamic output performance which describes the output voltage variations that occur during changes in operating mode (first character – i.e. when transferring between normal, bypass, and stored energy operating modes) and with the application or removal of load (second character).

Voltage variations fall into one of three classifications⁴:

- 1: No interruption with $\pm 20\%$ voltage regulation in < 10 ms
- 2: Up to 1 ms of interruption with $\pm 20\%$ voltage regulation in < 10 ms
- 3: Up to 10 ms of interruption with $+10\%$, -20% voltage regulation in < 100 ms

In summary, a UPS's output performance can be described in 3 parts: input dependency (AAA), output voltage waveform (BB), and dynamic output performance (CC). The complete output performance can thus be summarized as: AAA-BB-CC (i.e. VFD-SY-33, VI-SS-31, VFI-SS-11). For more details on this classification in IEC 62040-3, see **Appendix Table A1**.

⁴ See **Figures A5 – A7** in the Appendix for details.

UPS types

A variety of static UPS types are available in the market, and each has distinct performance characteristics. The most common types are as follows:

- Standby
- Line interactive
- Double conversion on-line
- Delta conversion on-line
- Hybrid conversion on-line

Many UPS types have multiple normal modes, which have different output performance characteristics based on the IEC standard. For example, a double conversion on-line UPS in on-line normal mode may have a VFI output performance, whereas in high-efficiency normal mode, it may have a VFD output performance.

There are three common modes of operation:

- **Normal mode** – The UPS powers the load using the AC input power source and the energy storage device (e.g. battery, flywheel, etc.) is connected and is either charging or fully charged.
- **High-efficiency normal mode** – The UPS powers the load directly from the AC input power source, for the purpose of increasing efficiency. The energy storage device is connected and is either charging or fully charged. Examples of high efficiency modes include bypass normal mode and power factor corrected (PFC) bypass normal mode. For more information see White Paper 157, [Eco-mode: Benefits and Risks of Energy-saving Modes of UPS Operation](#).
- **Stored energy mode (battery mode)** – The UPS powers the load using DC power from the energy storage device because the AC input power source is interrupted or is outside of the acceptable voltage or frequency ranges.

It is important to note that nearly all UPSs which offer a high efficiency normal mode will automatically change between high efficiency and standard normal mode to achieve the optimal balance between efficiency and load protection. Examples of this behavior are explained in detail in the **Appendix**.

All types of UPSs have normal mode and stored energy mode while just a few types offer high-efficiency normal mode (as shown in **Table 2**). Other than waveform, the output performance in stored energy mode is similar for all UPS types, therefore we will not discuss it in depth in this paper.

Table 2

High-efficiency normal mode availability by UPS type

UPS types	High-efficiency normal mode	
	Bypass	PFC bypass
Standby	*	×
Line interactive	**	×
Double conversion on-line	✓	✓
Delta conversion on-line	✓	×
Hybrid conversion on-line	✓	×

* Standby UPSs can be considered to have bypass normal mode as their only normal mode.

** Many Line interactive UPSs can de-energize their automatic voltage regulation (AVR) transformers and essentially operate in bypass normal mode when doing so.

The following subsections summarize each type of UPS with a brief description, topology diagram, benefits, limitations, and IEC output performance.

Standby UPS

Standby UPSs are commonly used to protect individual loads like desktop computers. As shown in the block diagram of **Figure 1**, the transfer switch is set to choose the AC input as the power source (solid line path), and switches to the battery / inverter⁵ as the backup source should the primary source fail. When that happens, the transfer switch must operate to switch the load over to the battery / inverter backup power source (dashed path). The inverter only starts when the power fails, hence the name "standby".

Low cost, small size, non-sinusoidal output waveforms, and high efficiency are typical attributes of this UPS type. Some standby UPSs also provide surge suppression and electrical noise filtration.

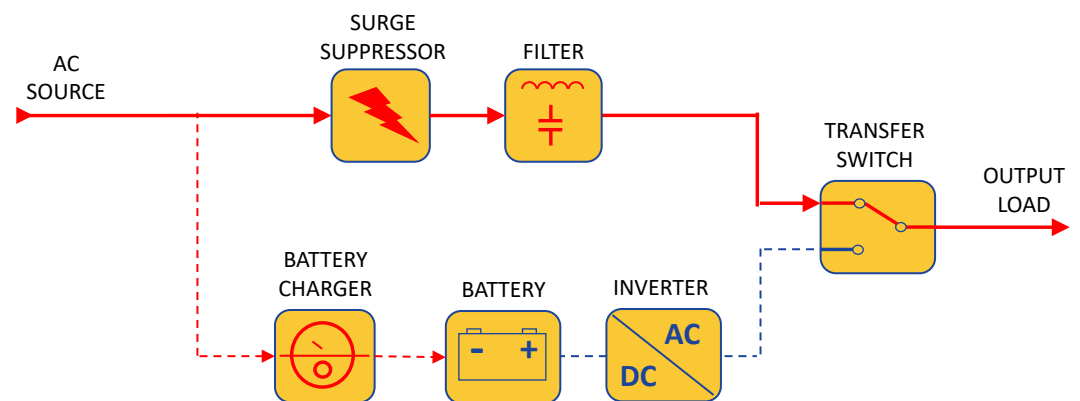

Figure 1
Normal mode – standby
UPS topology

IEC output performance

Because a standby UPS lacks circuitry to regulate output voltage or frequency in normal mode, the IEC standard classifies the input dependency as Voltage and Frequency Dependent (VFD). Because it passes the sinusoidal AC input voltage through to the load in normal mode and commonly utilizes a square or step wave inverter in stored energy mode, the IEC standard classifies the output waveforms as SY. Because it typically takes almost 10 ms to detect a power failure, move the transfer switch, and turn on the inverter; and because the inverter doesn't handle step loads well, the IEC standard classifies the dynamic output performance as 33. The complete output performance is summarized as VFD-SY-33. See the **Appendix** for more details.

⁵ An inverter is an electronic device that converts DC voltage into AC voltage.

Line interactive UPS

Line Interactive UPSs are commonly used to protect small quantities of important servers and associated networking equipment. As shown in the block diagram of **Figure 2**, the battery-to-AC power converter⁶ (inverter) is always connected to the output of the UPS. Operating the inverter in reverse during times when the input AC power is normal provides battery charging.

When the input power fails, the transfer switch opens and the power flows from the battery to the UPS output. With the inverter always on and connected to the output, this design provides additional filtering and yields reduced switching transients when compared with the standby UPS topology.

In addition, the line interactive design usually incorporates a tap-changing AVR transformer. This adds voltage regulation by adjusting transformer taps as the input voltage varies. Voltage regulation is an important feature when low voltage conditions exist, otherwise the UPS would transfer to battery and then eventually shut-down the load. This more frequent battery usage can cause premature battery failure. However, the inverter can also be designed such that its failure will still permit power flow from the AC input power source to the load, which eliminates the potential of single point failure and effectively provides for two independent power paths.

Low cost, small size, sinusoidal output waveforms, high efficiency, and high reliability coupled with the ability to correct low or high line voltage conditions make this the dominant type of UPS in the 0.5-5 kVA power range.

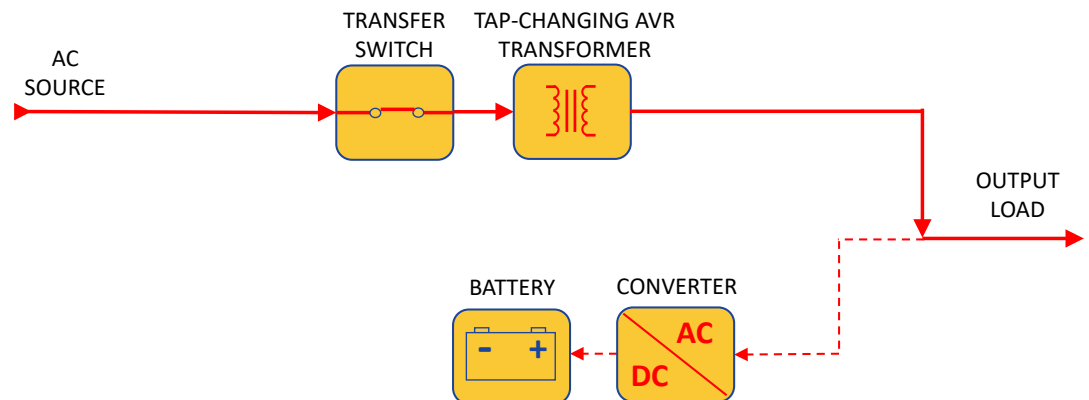

Figure 2
Normal mode – line interactive UPS topology

IEC output performance

Because a line interactive UPS commonly includes an AVR transformer to regulate output voltage in normal mode, but it cannot regulate frequency, the IEC standard classifies the input dependency as Voltage Independent (VI). Because it passes the sinusoidal AC input voltage through to the load in normal mode and commonly utilizes a sine wave inverter in stored energy mode, the IEC standard classifies the output waveforms as SS. Because it typically takes almost 10 ms to detect a power failure, move the transfer switch, and reverse the power flow through the inverter; and because the inverter handles step loads well, the IEC standard classifies the dynamic output performance as 31. The complete output performance is summarized as VI-SS-31. See the **Appendix** for more details.

⁶ Converter is a term that describes a rectifier or inverter that processes power bi-directionally.

Double conversion on-line UPS

Double conversion UPSs are the most popular type above 10kVA, and they are commonly used to protect large quantities of critical servers and associated storage and networking equipment. While the standby and line interactive UPS types discussed above have two modes of operation (e.g. normal and battery modes), double conversion UPSs often have one or two additional normal modes; a high-efficiency bypass normal mode and/or a high-efficiency PFC (Power Factor Corrected) bypass normal mode. The following subsections describe each operating mode with respect to power flow, transfer characteristics, and IEC output performance.

On-line normal mode – The double conversion on-line UPS block diagram illustrated in **Figure 3** is similar to that of a standby UPS, except the power path to the load is through the PFC rectifier⁷ and the inverter instead of through a transfer switch fed from the AC input power source. When the input power fails, the rectifier shuts down and the inverter draws power from the battery to supply the load. Because the power path doesn't change, no switches operate, which results in no interruption of power to the load (i.e. 0 ms transfer time).

A double conversion UPS operating in on-line normal mode provides nearly ideal electrical output performance. It draws sinusoidal current from the AC input power source and it provides low distortion, nominal amplitude and frequency, sinusoidal voltage to the load.

Figure 3
On-line normal mode –
double conversion on-line
UPS topology

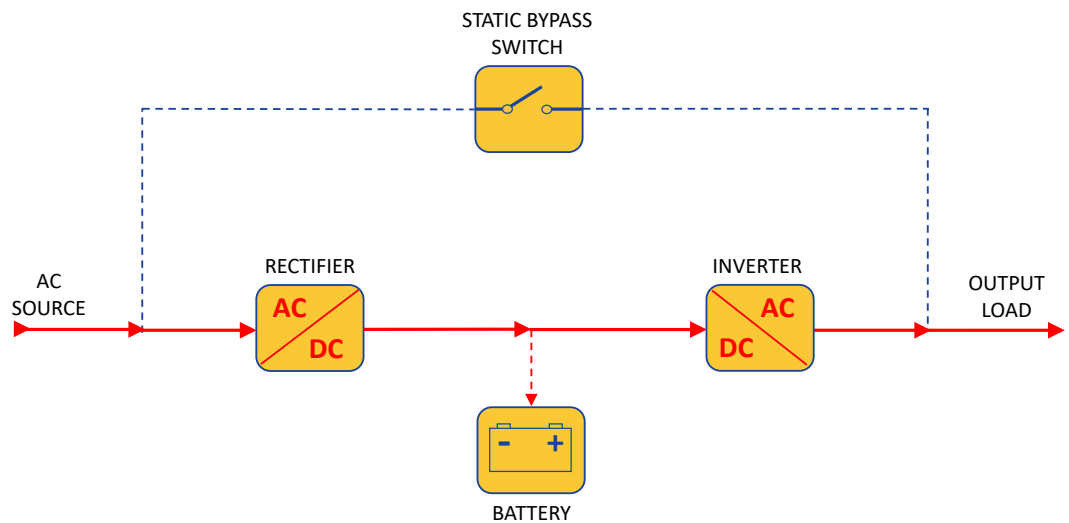

IEC output performance

Because a double conversion on-line UPS operating in on-line normal mode can regulate both output voltage and frequency, the IEC standard classifies the input dependency as Voltage and Frequency Independent (VFI). Because the sine wave inverter powers the load in both normal and stored energy modes, the IEC standard classifies the output waveforms as SS. Because the inverter continuously supplies power to the load during a power failure, and because the inverter handles step loads well, the IEC standard classifies the dynamic output performance as 11. The complete output performance is summarized as VFI-SS-11. See the **Appendix** for more details.

⁷ A rectifier is an electronic device that converts AC voltage into DC voltage.

Bypass normal mode – The block diagram in **Figure 4** illustrates that in bypass normal mode, the power path to the load is through the static bypass⁸ switch, the rectifier only operates at low power to charge the battery, and the inverter is in standby. This improves the efficiency of the UPS and extends its service life, due to reduced heat and component stresses. When the power fails, the static bypass switch opens, and the inverter draws power from the battery to supply the load.

Figure 4
Bypass normal mode – double conversion on-line UPS topology

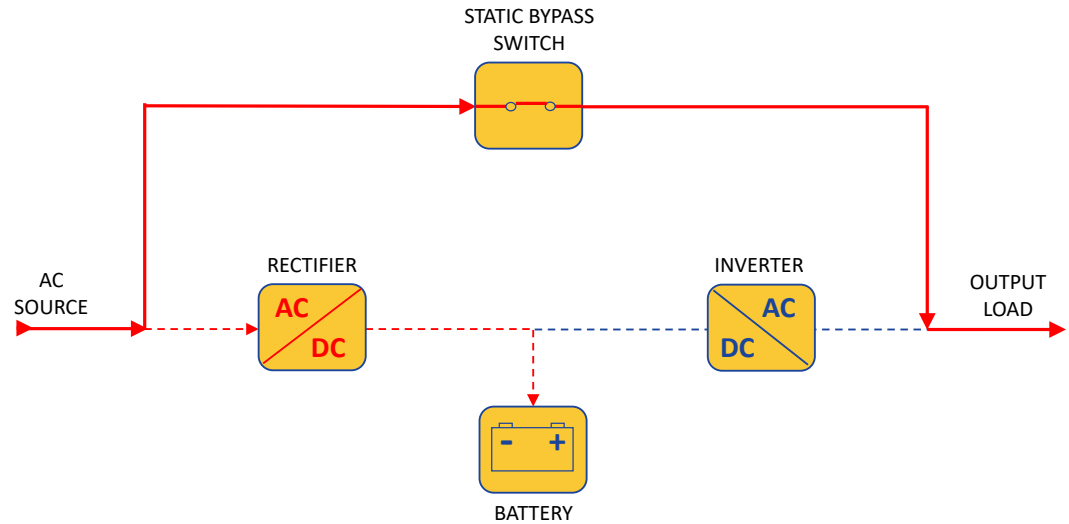

IEC output performance

Because a double conversion on-line UPS operating in bypass normal mode cannot regulate either output voltage or frequency, the IEC standard classifies its input dependency as Voltage and Frequency Dependent (VFD). Because it passes the sinusoidal AC input voltage through to the load in bypass normal mode and the sine wave inverter is used in stored energy mode, the IEC standard classifies the output waveforms as SS. Because it typically takes almost 10 ms to detect a power failure, open the static bypass switch, and start the inverter; and because the inverter handles step loads well, the IEC standard classifies the dynamic output performance as 31. The complete output performance is summarized as VFD-SS-31. See the **Appendix** for more details.

⁸ As the name indicates, load power bypasses the conversion process.

PFC bypass normal mode – Similar to standard bypass normal mode, the primary power path in PFC bypass normal mode is through the bypass path. However, as the block diagram in **Figure 5** illustrates, the inverter remains on-line providing the required current to ensure that the AC input power source sees only sinusoidal current with high power factor. PFC bypass normal mode eliminates the primary drawbacks of standard bypass normal mode by reducing transfer time to 0ms and providing PFC input current while achieving nearly the same efficiency.

Figure 5
PFC bypass normal
mode – double conver-
sion on-line UPS topol-

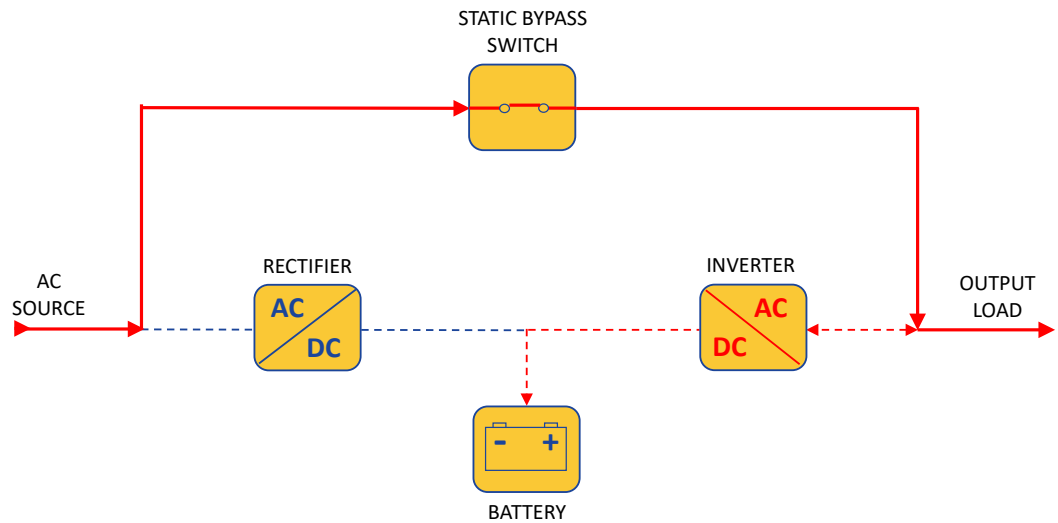

IEC output performance

When in PFC bypass normal mode, the output performance is similar to standard bypass normal mode except that, because the inverter is always operating, there is no interruption of power to the load during a power failure. Therefore, the output performance is classified as VFD-SS-11. See **Appendix** for more details.

Delta conversion on-line UPS

Delta conversion is a mature technology invented to provide higher on-line efficiency than double conversion. It has three modes of operation including on-line normal mode, bypass normal mode, and battery mode. The following subsections describe each operating mode with respect to power flow, transfer characteristics, and IEC output performance.

On-line normal mode – The block diagram for a delta conversion on-line UPS in normal mode is illustrated in **Figure 6**. Similar to a double conversion on-line UPS, in normal mode, the delta conversion on-line UPS always has the main converter supplying voltage to the load. However, the additional delta converter also passes power to the load. Under conditions of AC failure or voltage disturbances, this design exhibits behavior identical to a double conversion on-line UPS.

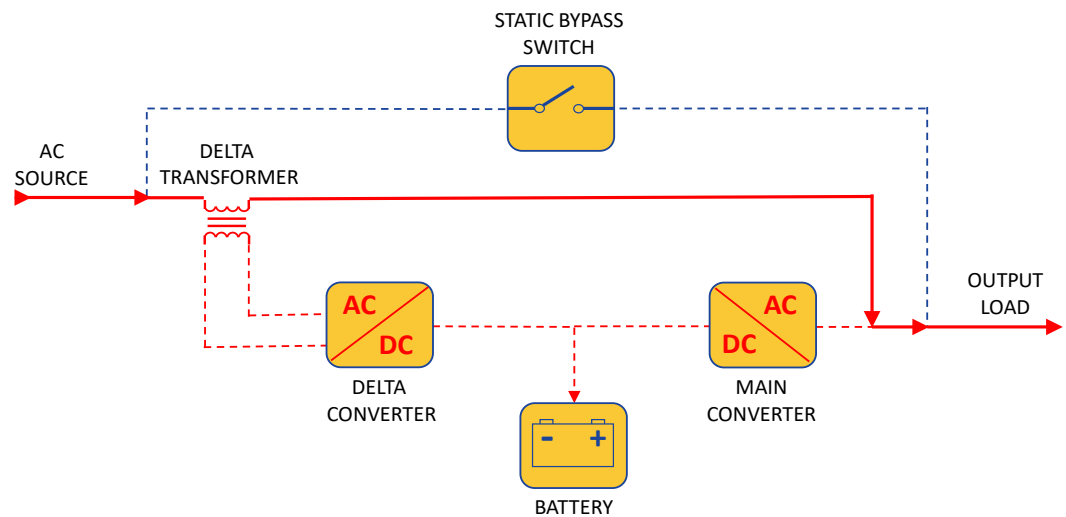

Figure 6
On-line normal mode –
delta conversion on-
line UPS topology

A simple way to understand delta conversion is to consider the energy required to deliver a package from the 4th floor to the 5th floor of a building as shown in **Figure 7**. Delta conversion on-line technology saves energy by carrying the package only the difference (delta) between the starting and ending points. The double conversion on-line UPS converts the power to the battery and back again whereas the delta converter moves components of the power from input to the output.

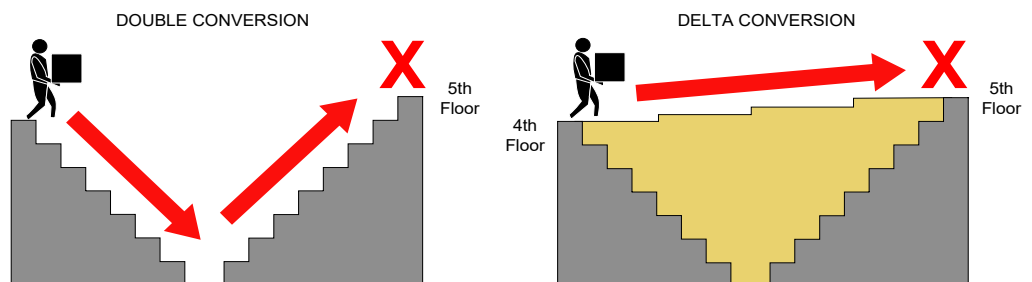

Figure 7
Analogy of double
conversion on-line
vs. delta conversion
on-line UPS

IEC output performance

Because a delta conversion on-line UPS uses a delta converter to regulate output voltage in normal mode, but cannot regulate frequency, the IEC standard classifies the input dependency as Voltage Independent (VI). Because the delta converter supplies sinusoidal voltage to the load in normal mode and the sine wave main converter is used in stored energy mode, the IEC standard classifies the output waveforms as SS. Because the inverter continuously supplies power to the load during a power failure, and because the inverter handles step loads well, the IEC standard

classifies the dynamic output performance as 11. The complete output performance is summarized as VI-SS-11. See the **Appendix** for more details.

Bypass normal mode – The block diagram in **Figure 8** illustrates that in bypass normal mode, the power path to the load is through the static bypass switch, the main converter only operates at low power to charge the battery, and the delta converter is in standby. This improves the efficiency of the UPS and extends its service life, due to reduced heat and component stresses. When the power fails, the static bypass switch opens, and the main converter draws power from the battery to supply the load.

Figure 8
Bypass normal mode
– delta conversion
on-line UPS topology

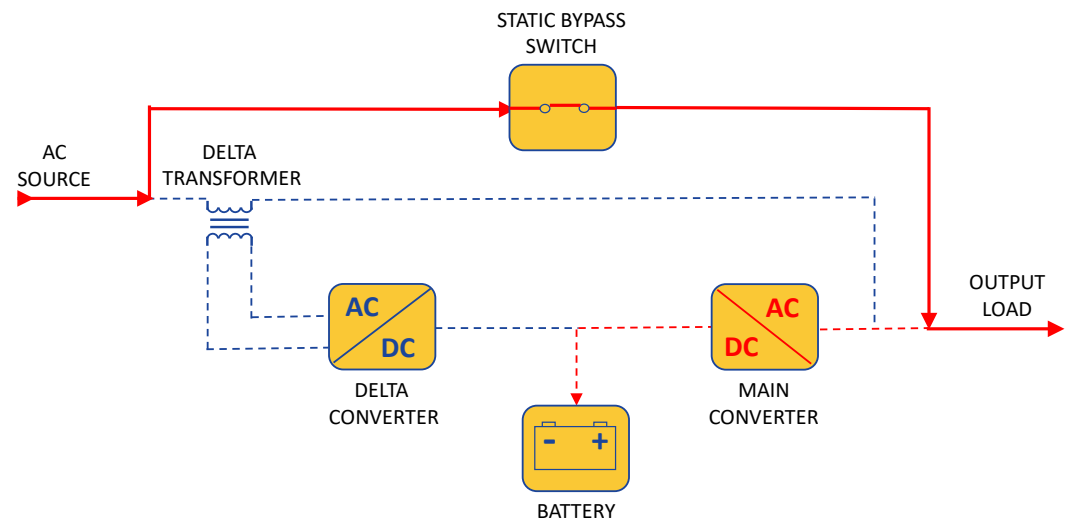

IEC output performance

Because a delta conversion on-line UPS operating in bypass normal mode cannot regulate either output voltage or frequency, the IEC standard classifies its input dependency as Voltage and Frequency Dependent (VFD). Because it passes the sinusoidal AC input voltage through to the load in bypass normal mode and the sine wave main converter is used in stored energy mode, the IEC standard classifies the output waveforms as SS. Because it typically takes almost 10 ms to detect a power failure, open the static bypass switch, and start the main converter (and because the main converter handles step loads well), the IEC standard classifies the dynamic output performance as 31. The complete output performance is summarized as VFD-SS-31. See the **Appendix** for more details.

Hybrid conversion on-line UPS

Hybrid conversion is a relatively new technology intended to provide higher density than double conversion while providing similar electrical performance. It is ideal for protecting small quantities of sensitive servers and associated networking equipment in dense edge environments. It has three modes of operation including on-line normal mode, bypass normal mode, and battery mode. The following subsections describe each operating mode with respect to power flow, transfer characteristics, and IEC output performance.

On-line normal mode – The hybrid conversion block diagram illustrated in **Figure 9** is similar to a double conversion on-line UPS, except that the power path to the load flows through a hybrid converter (i.e. integrated rectifier and inverter) in place of a separate rectifier and inverter. This integrated design provides voltage regulation but trades-off frequency regulation capability in favor of reduced component quantity. When the input power fails, the rectifier portion of the hybrid converter shuts down and the inverter draws power from the battery to supply the load. Because the power path doesn't change, no switches operate, which results in no interruption of power to the load (i.e. 0 ms transfer time).

Except for the lack of frequency regulation, a hybrid conversion UPS operating in on-line normal mode provides nearly ideal electrical output performance. It draws sinusoidal current from the AC input power source and it provides low distortion, nominal amplitude, sinusoidal voltage to the load.

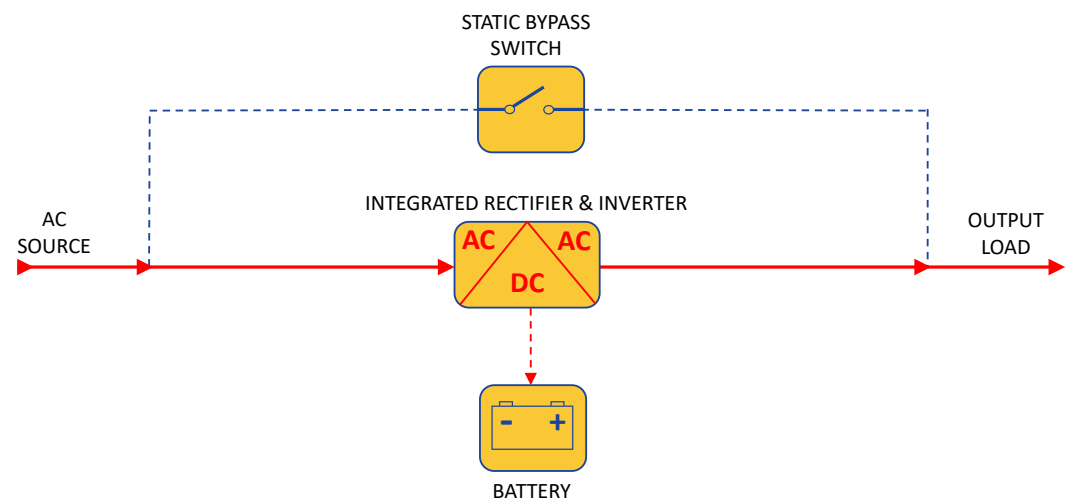

Figure 9
On-line normal mode –
hybrid conversion on-line
UPS topology

IEC output performance

Because a hybrid conversion on-line UPS uses a hybrid converter to regulate output voltage in normal mode, but it cannot regulate frequency, the IEC standard classifies the input dependency as Voltage Independent (VI). Because the hybrid converter supplies sinusoidal voltage to the load in normal and stored energy modes, the IEC standard classifies the output waveforms as SS. Because the inverter continuously supplies power to the load during a power failure, and because the inverter handles step loads well, the IEC standard classifies the dynamic output performance as 11. The complete output performance is summarized as VI-SS-11. See the **Appendix** for more details.

Bypass normal mode – The block diagram in **Figure 10** illustrates that in bypass normal mode, the power path to the load is through the static bypass switch, the rectifier portion of the hybrid converter only operates at low power to charge the battery and keep the inverter ready to power the load. This improves the efficiency of the UPS and extends its service life, due to reduced heat and component stresses. When the power fails, the static bypass switch opens, and the inverter draws power from the battery to supply the load.

Figure 10
Bypass normal mode
– hybrid conversion
on-line UPS topology

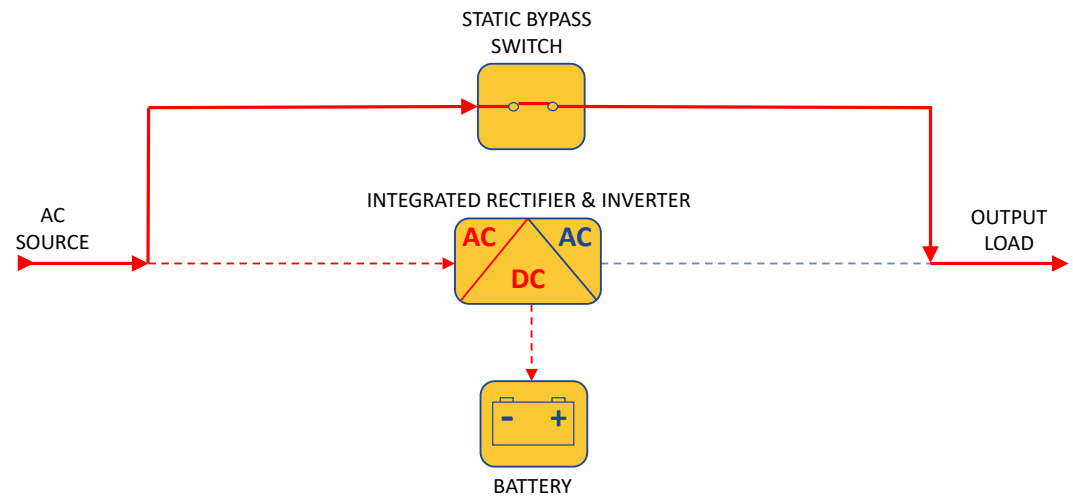

IEC output performance

Because a hybrid conversion on-line UPS operating in bypass normal mode cannot regulate either output voltage or frequency, the IEC standard classifies its input dependency as Voltage and Frequency Dependent (VFD). Because it passes the sinusoidal AC input voltage through to the load in normal mode and the sine wave inverter is used in stored energy mode, the IEC standard classifies the output waveforms as SS. Because it typically takes almost 10 ms to detect a power failure, open the static bypass switch, and start the inverter; and because the inverter handles step loads well, the IEC standard classifies the dynamic output performance as 31. The complete output performance is summarized as VFD-SS-31. See the **Appendix** for more details.

Summary of UPS types

Table 3 summarizes the main characteristics of the five UPS types discussed in this paper. Some attributes of a UPS, like efficiency, are dictated by the choice of UPS type. Since implementation and manufactured quality more strongly impact characteristics such as reliability, these factors must be evaluated in addition to these design attributes.

Table 3

Summary of typical characteristics of the five UPS types

UPS Type	Standby	Line Interactive	Double Conversion On-line			Delta Conversion On-line		Hybrid Conversion On-line	
Operating Mode	Normal	Normal	Normal	Bypass	PFC Bypass	Normal	Bypass	Normal	Bypass
Typical power range	0.2 – 2kVA	0.5 – 5kVA	1 – 1500kVA			5 – 1600kVA		1 – 3kVA	
Cost per VA*	Low	Medium	High			High		High	
Power density	Very High	Medium	Medium			Medium		High	
Service life	Short	Medium	Long			Long		Long	
Load criticality	Low	High	Very High			Very High		High	
Efficiency	Very High	Very High	Medium	Very High	Very High	High	Very High	Medium	High
Inverter on-line	No	Depends**	Yes	No	Yes	Yes	No	Yes	No
Power factor corrected input current	No	No	Yes	No	Yes	Yes	No	Yes	No
Output voltage window	Wide	Wide	Narrow	Wide	Wide	Narrow	Wide	Narrow	Wide
Output frequency window	Wide	Wide	Narrow	Narrow	Narrow	Wide	Wide	Wide	Wide
Inverter waveform	Square, Step-sine	Step-sine, Sine	Sine			Sine		Sine	
Transfer time	<10 ms	<10 ms	0 ms	<10 ms	0 ms	0 ms	<10 ms	0 ms	<10 ms
IEC classification	VFD-SY-33, VFD-SX-33	VI-SX-31, VI-SS-31	VFI-SS-11	VFD-SS-31	VFD-SS-11	VI-SS-11	VFD-SS-31	VI-SS-11	VFD-SS-31

* Relative cost assuming equivalent power rating, runtime, semiconductor technology, battery type, etc.

** Converter operates with reverse power flow when charging batteries at a high rate

Use of UPS types in the industry

The UPS industry product offering has evolved over time to include many of these designs. The different UPS types have attributes that make them more or less suitable for different applications and the APC by Schneider Electric product line reflects this diversity as shown in **Table 4**. Energy efficiency optimization has also played a large role in UPS designs. For example, most UPS systems do not include the internal transformers that were present in earlier designs. This evolution has increased efficiency while decreasing the weight, size, and raw material consumption of UPS systems. Bypass normal mode is another example of energy efficiency optimization, but it does come with some cost / benefit tradeoffs. Compared with standard bypass normal mode, PFC bypass normal mode can achieve high energy efficiency while reducing the transfer time to 0 ms. For more information on these two topics, see White Paper 98, [The Role of Isolation Transformers in Data Center UPS Systems](#) and White Paper 157, [Eco-mode: Benefits and Risks of Energy-saving Modes of UPS Operation](#). High power density is an important trend to reduce UPS footprint and is preferred for some applications such as the edge computing.

Table 4

Commercially available UPS types, benefits, and limitations

UPS Type	Commercially available products	Benefits	Limitations	APC's findings
Standby	APC Back-UPS	Low cost, very high efficiency, compact size	Operates on battery during brownouts, impractical over 2kVA	Best value for personal computers
Line interactive	APC Back-UPS Pro, APC Smart-UPS	High reliability, very high efficiency, AVR enables normal mode operation over a wide input voltage range	Impractical over 5kVA	Most popular UPS type in existence due to high reliability, ideal for rack or distributed servers
Double conversion on-line	APC Smart-UPS On-line, Galaxy, Easy UPS 3-Phase, Gutor PXC, PXP, PXW	Excellent voltage conditioning, ease of paralleling, available high efficiency modes	Expensive under 5kVA	Industry standard for mission critical applications, well suited for redundant designs
Delta conversion on-line	Symmetra MW	Excellent voltage conditioning, high efficiency	Impractical under 5kVA	High efficiency reduces the lifetime cost of energy in large installations
Hybrid conversion on-line	APC Smart-UPS Ultra	Excellent voltage conditioning, high power density, 0 ms transfer time, PFC, available high efficiency mode	Impractical over 5kVA	High power density reduces rack space requirement, excellent load compatibility and protection

Conclusion

There are many different types of UPSs available in the market today. The IEC performance standard is a means to characterize the performance of each UPS type in each operating mode. Only by understanding performance and other attributes, can the optimal UPS be selected for a given application.

About the authors

Jim Spitaels is the Director of Emerging Technologies and a Senior Edison Expert in the Secure Power Business of Schneider Electric. He has more than 30 years' experience in the field of power protection and holds more than 50 patents on power system, UPS, rack and communications protocol design and is active in the development of IEC standards and energy efficiency programs. Jim holds both bachelor's and master's degrees in Electrical Engineering from Worcester Polytechnic Institute.

Linda Zhang is a Research Analyst at Schneider Electric's Science Center. She is responsible for data center design and operation research. She joined Schneider Electric in 2011 and had over 15 years of experience in data center industry. Before joining Schneider Electric, Linda worked as a data center design engineer and accumulated rich experience in electrical engineering and standards. Linda holds a bachelor's degree in Electrical Engineering Automation and her MBA from University of Science and Technology Beijing. She is also an Accredited Tier Designer (ATD) of Uptime Institute and a qualified engineer of power grid.

Paul Lin is the Research Director at Schneider Electric's Science Center. He is responsible for data center design and operation research and consults with clients on risk assessment and design practices to optimize the availability and efficiency of their data center environment. Before joining Schneider Electric, Paul worked as the R&D Project Leader in LG Electronics for several years. He is now designated as a "Data Center Certified Associate", an internationally recognized validation of the knowledge and skills required for a data center professional. He is also a registered HVAC professional engineer. Paul holds a master's degree in Mechanical Engineering from Jilin University with a background in HVAC and Thermodynamic Engineering.

Acknowledgements

Special thanks to **Neil Rasmussen** for authoring the original content of this white paper.

RATE THIS PAPER





[The Seven Types of Power Problems](#)

White Paper 18



[The Role of Isolation Transformers in Data Center UPS Systems](#)

White Paper 98



[Eco-mode: Benefits and Risks of Energy-saving Modes of UPS Operation](#)

White Paper 157



[Browse all](#)

[white papers](#)

whitepapers.apc.com



[Browse all](#)

[TradeOff Tools™](#)

tools.apc.com



Contact us

For feedback and comments about the content of this white paper:

Data Center Science Center

dcsc@schneider-electric.com

If you are a customer and have questions specific to your data center project:

Contact your Schneider Electric representative at

www.apc.com/support/contact/index.cfm

Appendix

In order to explain the performance of the various types of UPSs, in each of their operating modes, detailed explanations and graphs are provided to illustrate how the output voltage and frequency of each type vary with input voltage and frequency in each supported normal mode.

For these examples, we selected 230 V and 50 Hz as the nominal UPS output voltage and frequency, but the graphs would look similar for other nominal values and allowed tolerances.

Voltage and frequency dependent (VFD)

Voltage and frequency dependent UPSs cannot regulate their output voltage or output frequency in normal mode.

Standby UPS – In normal mode, the output voltage of a standby UPS equals its input voltage when the input voltage stays within the allowed output range (e.g. $\pm 10\%$ of nominal). When the input voltage exceeds this range, the UPS will transfer from normal mode to battery mode and its inverter will provide the nominal 230 V output voltage to the load, until the input voltage returns within the normal mode range or its battery is depleted. See **Figure A1 (a)**.

Figure A1 (a) and (b)

Example of output voltage and frequency dependency for a standby (VFD) UPS

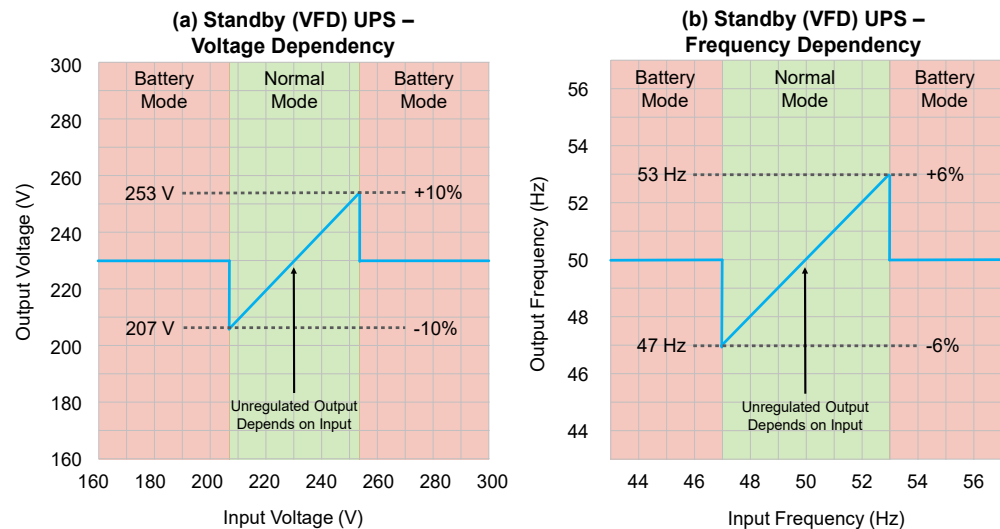

The frequency dependency behavior of a standby UPS is similar to that of voltage. In normal mode, the output frequency of a standby UPS equals its input frequency when the input frequency stays within the allowed output range (e.g. $\pm 6\%$ of nominal). When the input frequency exceeds this range, the UPS will transfer from normal mode to battery mode and its inverter will provide the nominal 50 Hz output frequency to the load, until the input frequency returns within the normal mode range or its battery is depleted. See **Figure A1 (b)**.

Because of their inability to regulate output voltage or output frequency, standby UPSs are best suited for locations with good power quality and for loads that are not very sensitive to voltage or frequency variations.

Voltage independent (VI)

Voltage Independent UPSs can regulate their output voltage, but they cannot regulate their output frequency in normal mode. The different types of VI UPSs regulate output voltage differently.

Line interactive UPS – In normal mode, the output voltage of a line interactive VI UPS equals its input voltage when the input voltage stays within the allowed output range (e.g. $\pm 10\%$ of nominal). When the UPS operates within this range, the AVR transformer is typically de-energized which results in maximum efficiency. When the input voltage exceeds this range, the UPS will stay in normal mode and energize its AVR transformer to either ratiometrically increase (e.g. $V_{out} = 1.1 \times V_{in}$) or decrease (e.g. $V_{out} = 0.9 \times V_{in}$) the input voltage to create an output voltage within the allowed range. When the input voltage exceeds the compensation range of the AVR transformer (e.g. $> \pm 20\%$ of nominal), the UPS will transfer to battery mode and the inverter will provide the nominal 230 V output voltage to the load, until the input voltage returns within the normal mode range or its battery is depleted. See **Figure A2 (a)**.

Figure A2 (a) and (b)

Examples of output voltage independency for VI UPSs

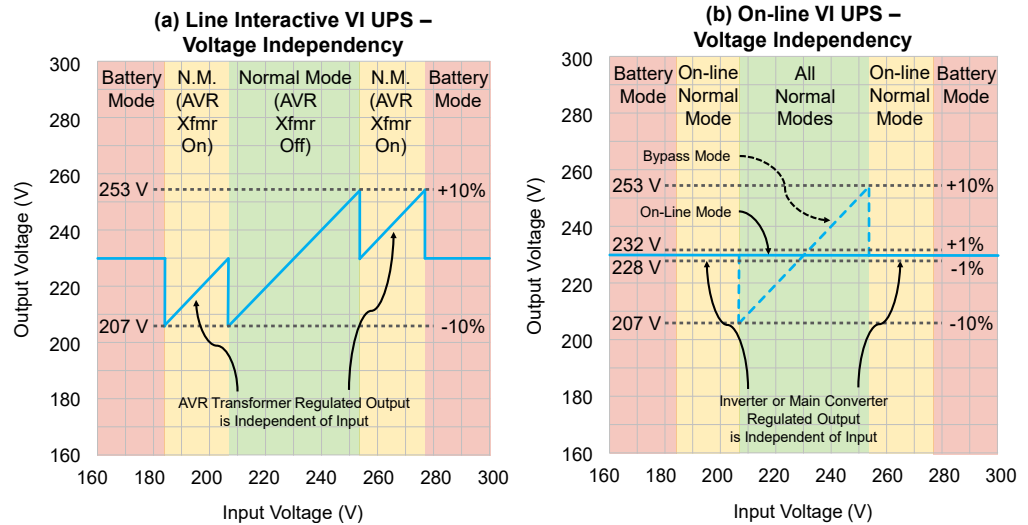

Delta and hybrid conversion on-line UPS in eco-mode – In eco-mode, an on-line VI UPS will utilize both bypass normal mode and on-line normal mode. When in bypass normal mode, the output voltage of an on-line VI UPS equals its input voltage when the input voltage stays within the allowed output range (e.g. $\pm 10\%$ of nominal). When the UPS operates within this range, the bypass path is used to power the load which results in maximum efficiency. When the input voltage exceeds this range, the UPS will transfer from bypass normal mode to on-line normal mode and the integrated rectifier-inverter or main converter will be used to provide the nominal 230 V output voltage to the load. When the input voltage exceeds the operational input range of the rectifier or delta converter (e.g. $> \pm 20\%$ of nominal), the UPS will transfer from on-line normal mode to battery mode and the inverter or main converter will provide the nominal 230 V output voltage to the load, until the input voltage returns within the normal mode range or its battery is depleted. See the dashed blue line in **Figure A2 (b)**.

Delta and hybrid conversion on-line UPS in on-line normal mode – In on-line normal mode, when the input voltage stays within the operational input range of its rectifier or delta converter (e.g. $\pm 20\%$ of nominal), an on-line VI UPS will utilize its integrated rectifier-inverter or main converter to provide the nominal 230 V output voltage to the load. This is done, at the cost of lowering efficiency, to ensure that the load is always supplied with a low distortion sinewave at the nominal voltage. When the input voltage exceeds this range, the UPS will transfer from on-line normal mode to battery mode and the inverter or main converter will continue to provide the nominal 230 V output voltage to the load, until the input voltage returns within the normal mode range or its battery is depleted. See the solid blue line in **Figure A2 (b)**.

For all VI UPSs, the output frequency dependency behavior is like that of VFD UPSs. In all normal modes, the UPS's output frequency equals the input frequency when the input frequency stays within the allowed output range (e.g. $\pm 6\%$ of nominal). When the input frequency exceeds this range, the UPS will transfer from normal mode to battery mode and the inverter or main converter will provide the nominal 50 Hz output frequency to the load, until the input frequency returns within the normal mode range or its battery is depleted. See **Figure A3**.

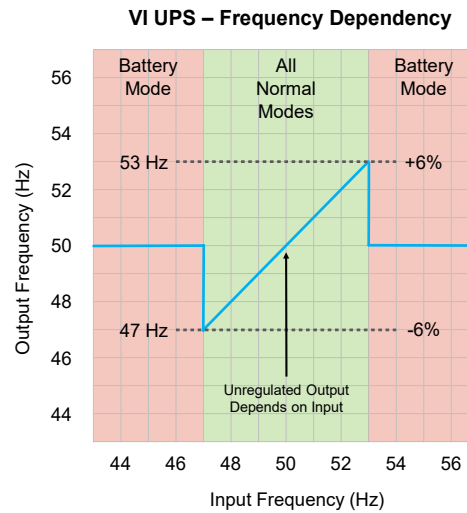

Figure A3

Example of output frequency dependency for a VI UPS

Because of their ability to regulate voltage and their inability to regulate frequency, VI UPSs are best suited for locations with moderate power quality and for loads that are sensitive to voltage variations but are not very sensitive to frequency variations.

Voltage and frequency independent (VFI)

Voltage and Frequency Independent UPSs can regulate both their output voltage and their output frequency in normal mode.

Double conversion on-line UPS in eco-mode – In eco-mode, an on-line VFI UPS will utilize both bypass normal mode and on-line normal mode. When in bypass normal mode, the output voltage of a VFI UPS equals its input voltage when the input voltage stays within the allowed output range (e.g. $\pm 10\%$ of nominal). When the UPS operates within this range, the bypass path is used to power the load which results in maximum efficiency. When the input voltage exceeds this range, the UPS will transfer from bypass normal mode to on-line normal mode and the rectifier and inverter will be used to provide the nominal 230 V output voltage to the load. When the input voltage exceeds the operational input range of the rectifier (e.g. $> \pm 20\%$ of nominal), the UPS will transfer from on-line normal mode to battery mode and the inverter will provide the nominal 230 V output voltage to the load, until the input voltage returns within the normal mode range or its battery is depleted. See the dashed blue line in **Figure A4 (a)**.

The eco-mode frequency dependency behavior of a VFI UPS is similar to that of voltage. When in bypass normal mode, the output frequency of a VFI UPS equals its input frequency when the input frequency stays within the typically narrow allowed output range (e.g. $\pm 2\%$ of nominal). When the UPS operates within this range, the bypass path is used to power the load which results in maximum efficiency. When the input frequency exceeds the allowed output frequency range, the UPS will transfer from bypass normal mode to on-line normal mode and the rectifier and inverter will be used to provide the load with the allowed output frequency nearest to the input frequency. The nearest allowed frequency, rather than the nominal, is output to

prevent the load from seeing an abrupt change in frequency during this transition. When the input frequency exceeds the operational input range of the rectifier (e.g. $> \pm 8\%$ of nominal), the UPS will transfer from on-line normal mode to battery mode and the inverter will provide the nearest allowed output frequency to the load, or the nominal 50 Hz output frequency if no input voltage is available, until the input frequency returns within the allowed normal mode range or its battery is depleted. See the blue line in **Figure A4 (b)**.

Double conversion on-line UPS in PFC EConversion™ mode – In EConversion mode, an on-line VFI UPS will utilize both PFC bypass normal mode and on-line normal mode. When in PFC bypass normal mode, the output voltage of a VFI UPS equals its input voltage when the input voltage stays within the allowed output range (e.g. $\pm 10\%$ of nominal). When the UPS operates within this range, the bypass path is used to power the load and the inverter will operate to ensure that input power factor is close to unity. When the input voltage exceeds this range, the UPS will transfer from PFC bypass normal mode to on-line normal mode and the rectifier and inverter will be used to provide the nominal 230 V output voltage to the load. When the input voltage exceeds the operational input range of the rectifier (e.g. $> \pm 20\%$ of nominal), the UPS will transfer from on-line normal mode to battery mode and the inverter will provide the nominal 230 V output voltage to the load, until the input voltage returns within the normal mode range or its battery is depleted. See the dashed blue line in **Figure A4 (a)**.

The EConversion mode frequency dependency behavior of a VFI UPS is similar to that of voltage. When in PFC bypass normal mode, the output frequency of a VFI UPS equals its input frequency when the input frequency stays within the typically narrow allowed output range (e.g. $\pm 2\%$ of nominal). When the UPS operates within this range, the bypass path is used to power the load and the inverter will operate to ensure that input power factor is close to unity. When the input frequency exceeds the allowed output frequency range, the UPS will transfer from PFC bypass normal mode to on-line normal mode and the rectifier and inverter will be used to provide the load with the allowed output frequency nearest to the input frequency. The nearest allowed frequency, rather than the nominal, is output to prevent the load from seeing an abrupt change in frequency during this transition. When the input frequency exceeds the operational input range of the rectifier (e.g. $> \pm 8\%$ of nominal), the UPS will transfer from on-line normal mode to battery mode and the inverter will provide the nearest allowed output frequency to the load, or the nominal 50 Hz output frequency if no input voltage is available, until the input frequency returns within the allowed normal mode range or its battery is depleted. See the blue line in **Figure A4 (b)**.

Figure A4 (a) and (b)
Examples of output voltage and frequency independency for a double conversion (VFI) UPS

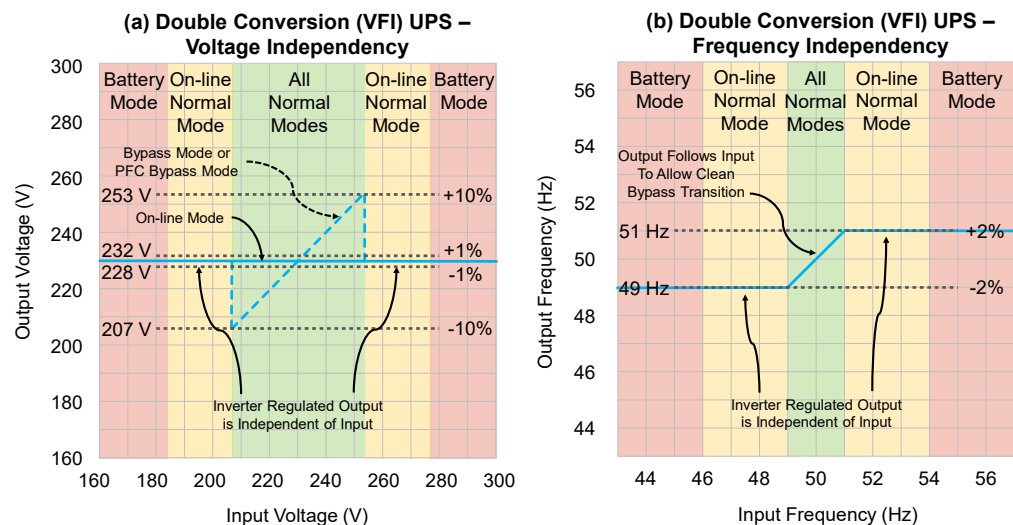

Double conversion UPS in on-line normal mode – In on-line normal mode, when the input voltage stays within the operational input range of its rectifier (e.g. $\pm 20\%$ of nominal), a VFI UPS will utilize its rectifier and inverter to provide the nominal 230 V output voltage to the load. This is done, at the cost of lowering efficiency, to ensure that the load is always supplied with a low distortion sinewave at the nominal voltage. When the input voltage exceeds this range, the UPS will transfer from on-line normal mode to battery mode and the inverter will continue to provide the nominal 230 V output voltage to the load, until the input voltage returns within the normal mode range or its battery is depleted. See the solid blue line in **Figure A4 (a)**.

The on-line normal mode frequency dependency behavior of a VFI UPS is similar to its behavior in eco-mode. When operating in on-line normal mode, the output frequency of a VFI UPS tracks its input frequency when the input frequency stays within the typically narrow allowed output range (e.g. $\pm 2\%$ of nominal). However, unlike in eco-mode, when the UPS operates within this range, the rectifier and inverter are used to power the load. This is done, at the cost of lowering efficiency, to ensure that the load never experiences an abrupt change in frequency or phase. When the input frequency exceeds this range, the rectifier and inverter will be used to provide the load with the allowed output frequency nearest to the input frequency. The nearest allowed frequency, rather than the nominal, is output to prevent the load from seeing an abrupt change in frequency during this transition. When the input frequency exceeds the operational input range of the rectifier (e.g. $> \pm 8\%$ of nominal), the UPS will transfer from on-line normal mode to battery mode and the inverter will provide the nearest allowed output frequency to the load, or the nominal 50 Hz output frequency if no input voltage is available, until the input frequency returns within the normal mode range or its battery is depleted. See **Figure A4 (b)**.

Because of their ability to regulate both voltage and frequency, VFI UPSs are best suited for locations with poor power quality and for loads that are sensitive to both voltage and frequency variations.

To better understand the three dynamic output performance classifications, **Figures A5 – A7** provide graphs to visualize their allowed voltage windows. Their most important characteristics are summarized below.

Class 3 – The output voltage has no upper bound during the initial 1 ms and it is allowed to be interrupted (i.e. 0V) during the initial 10 ms of the transient. It then gradually stabilizes to within +10% and -20% of nominal within 100 ms, as shown in the green region of **Figure A5**. This level of performance is acceptable to most general-purpose IT loads.

Figure A5

Dynamic output performance - allowed output voltage envelope for Class 3

Voltage Deviation (%)

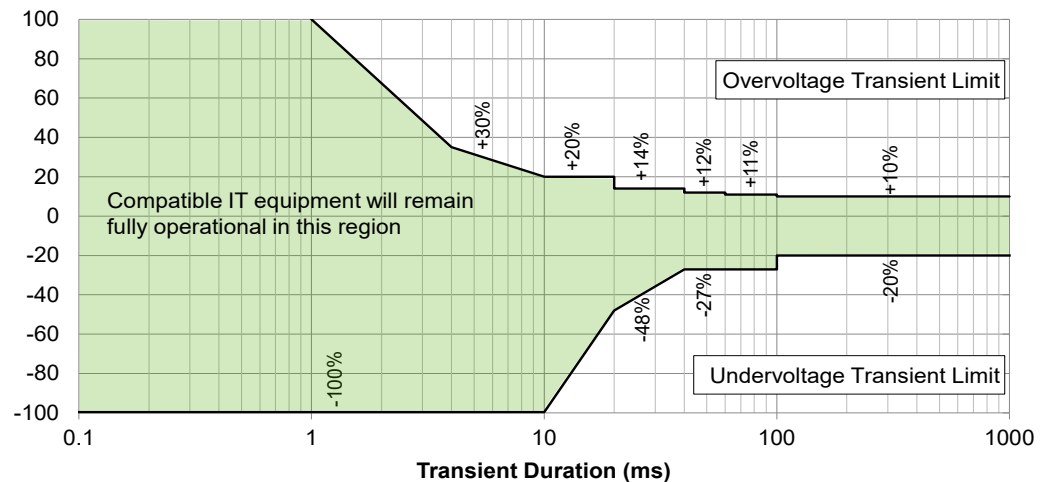

Class 2 – The output voltage has no upper bound and it is allowed to be interrupted (i.e. 0V) during the initial 1 ms of the transient. It then quickly stabilizes to within $\pm 20\%$ of nominal within 10 ms, and further stabilizes to within $\pm 10\%$ of nominal within 100 ms as shown in the green region of **Figure A6**. This level of performance is acceptable to most critical IT loads.

Figure A6

Dynamic output performance - allowed output voltage envelope for Class 2

Voltage Deviation (%)

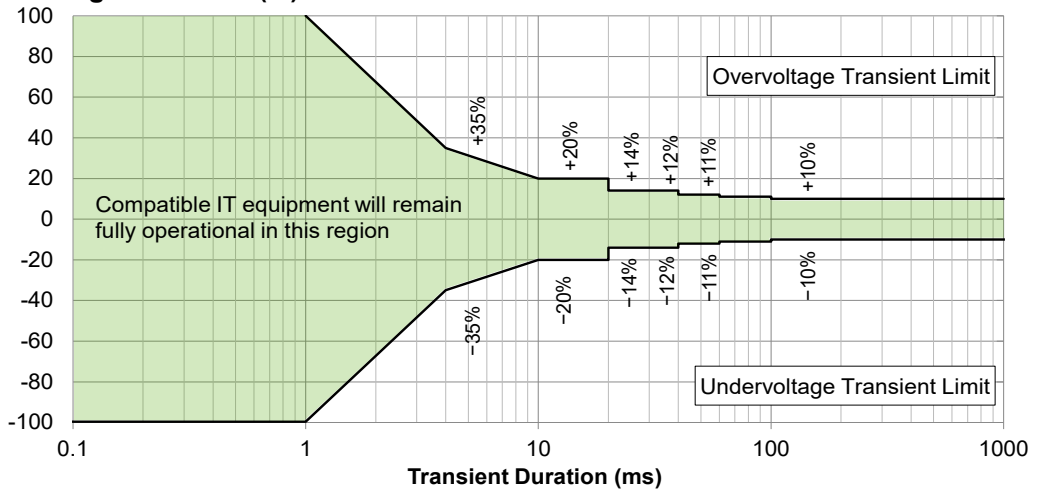

Class 1 – The output voltage is never interrupted during the transient. It stays within $\pm 30\%$ of nominal during the initial 5 ms, quickly comes within $\pm 20\%$ of nominal within 10 ms and further stabilizes to within $\pm 10\%$ of nominal within 100 ms as shown in the green region of **Figure A7**. This level of performance is acceptable to the most sensitive critical IT loads.

Voltage Deviation (%)

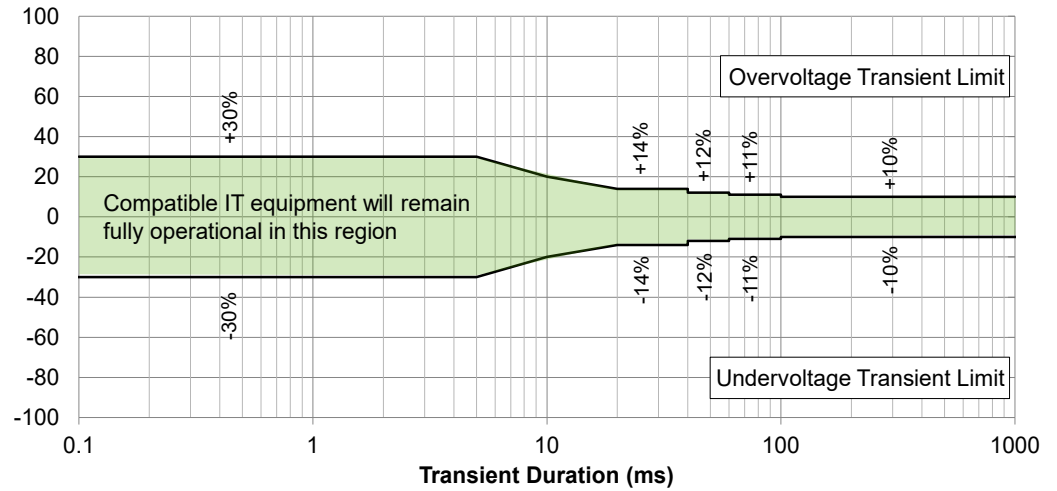

Figure A7

*Dynamic output performance
- allowed output voltage
envelope for Class 1*

Table A1 summarizes the IEC classifications for UPS output performance. The output performance is described in three parts: input dependency classification (AAA), output voltage waveform classification (BB), and dynamic output performance classification (CC). The complete output performance can thus be summarized as: AAA-BB-CC. The most common combinations available in the market are: VFD-SY-33, VI-SS-31, and VFI-SS-11.

Table A1

Summary of UPS output performance classifications based on the IEC 62040-3 standard

Output performance classifications							
Input dependency classification (AAA)			Output voltage waveform classification (BB)		Dynamic output performance classification (CC)		
V- Voltage, F-Frequency, D-Dependent, I-Independent			Normal mode (1st character)	Stored energy mode (2nd character)	Change of operating mode (1st character)	Step load application (2nd character)	
3 combinations: VFD/VI/VFI			9 possible combinations: SS/SX/SY/XS/XX/XY/YS/YX/YY		9 possible combinations: 11/12/13/21/22/23/31/32/33		
Definitions							
Type	Input voltage	Input frequency	Type	With linear and non-linear load applied in each operating mode	Class	Max output voltage interruption	Compatible load types
VFD	Dependent	Dependent	Y	Non-sinusoidal	3	10 ms	General-purpose IT loads
VI	Independent	Dependent	X	Sinusoidal with THD* ≤ 12 %, IHD** within limits ⁹	2	1 ms	Critical loads
VFI	Independent	Independent	S	Sinusoidal with THD* ≤ 8 %, IHD** within limits ¹⁰	1	0 ms	Sensitive critical loads

* THD means total harmonic distortion. ** IHD means individual harmonic distortion. Common combinations shown in **bold**.

⁹ IEC 62040-3:2021, Table 4

¹⁰ IEC 62040-3:2021, Table 3